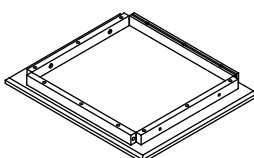
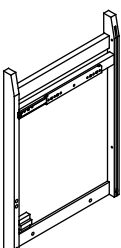
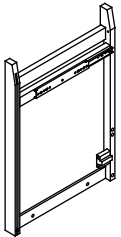
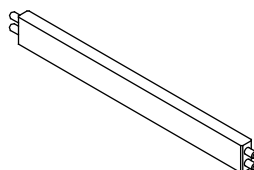
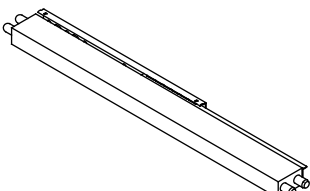

Assembly Instructions

ITEM Number : 717-9X
 Product Name: TROY CABINET

PRE-ASSEMBLY PREPARATION:

Please check all contents of this package before attempting to assemble the product. A full checklist of components is provided. If any components are missing, please contact the retailer from whom you have purchased this product. Read the Assembly Instructions in full before you begin to assemble. Please use CAUTION AND CARE WHEN LIFTING the product to avoid personal injury and (or) damage to the product. For ease of assembly, two people are recommended. The hardware packet contains SMALL ITEMS which should be KEPT AWAY FROM CHILDREN.

	PARTS	Qty
A	 <p>TABLE TOP</p>	1 PC
B	 <p>LEFT PANEL</p>	1 PC
C	 <p>RIGHT PANEL</p>	1 PC
D	 <p>FRONT BAR</p>	1 PC
E	 <p>MEDIUM BAR</p>	1 PC

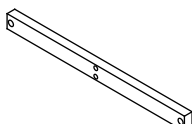
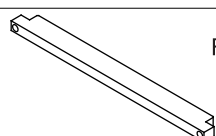
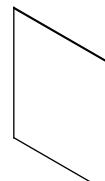
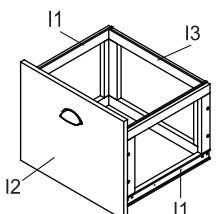
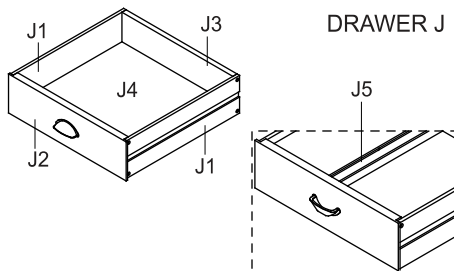
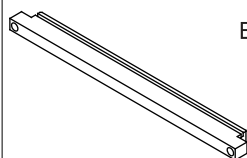

	PARTS	Qty
F	 <p>BACK BAR</p>	1 PC
G	 <p>FRONT SUPPORT BAR</p>	1 PCS
H	 <p>BACK PANEL</p>	1 PC
I	 <p>DRAWER I</p>	1 SET
J	 <p>DRAWER J</p>	1 SET
K	 <p>BACK SUPPORT BAR</p>	1 PCS

ITEM Number : 717-9X

Product Name: TROY CABINET

PRE-ASSEMBLY PREPARATION:

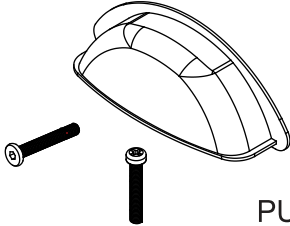
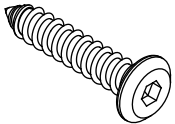
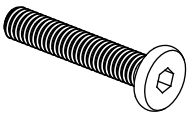
Please check all contents of this package before attempting to assemble the product. A full checklist of components is provided. If any components are missing, please contact the retailer from whom you have purchased this product. Read the Assembly Instructions in full before you begin to assemble. Please use **CAUTION AND CARE WHEN LIFTING** the product to avoid personal injury and (or) damage to the product. For ease of assembly, two people are recommended. The hardware packet contains **SMALL ITEMS** which should be **KEPT AWAY FROM CHILDREN**.

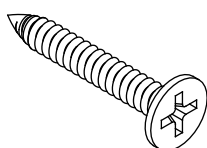
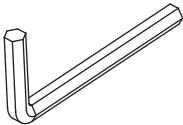
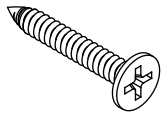
	PARTS	Qty
RF40140	 PULL HANDLE	2 SET
RF10003	 SCREWS JCA	6 PCS
RF10052	 SCREWS JCB	4 PCS
RF10029	 SCREWS F6 X 1/2"	6 PCS
RF10002	 SCREWS F6 X 1 1/4"	8 PCS
RF40103	 ALLEN KEY	1 PC
RF10019	 SCREWS F6 X 1"	8 PCS

REMARK : Attach Front Bar (D) and Back Bar (F) to Medium Bar (E) as show Diag (remark).

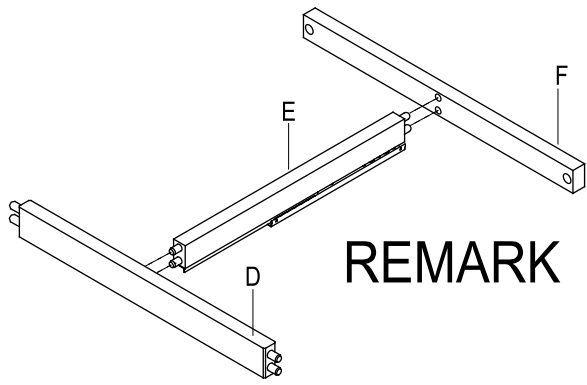

Step 1. Attach Left Panel (B) to Table Top (A) by using Screws JCB (RF10052) as show Diag 1.

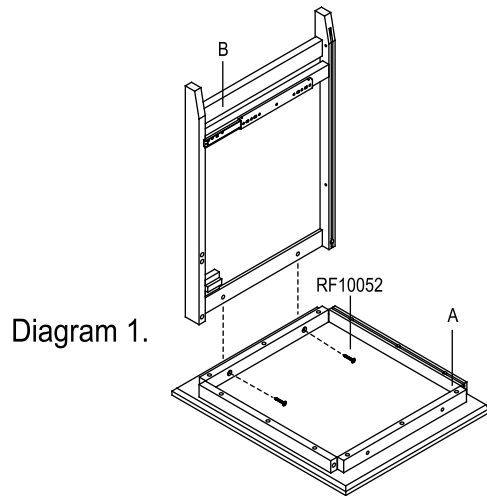

Step 2. Insert Back Bar (F) and Front Bar (D) to the Left Panel (B) by using Screws JCA (RF10003) as show Diag 2.

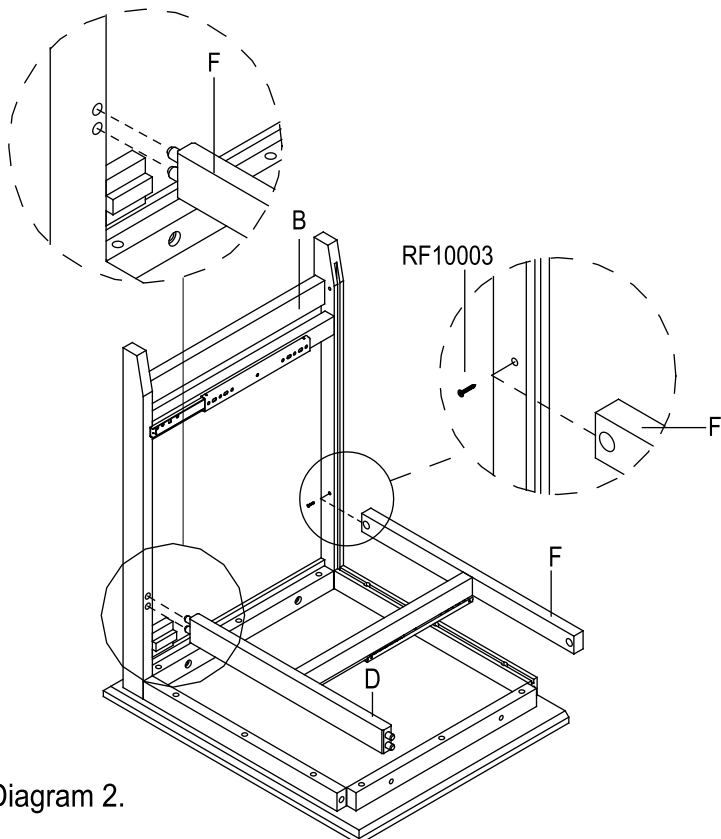

Step 3. Attach Front & Back support Bar (G,K) to Left Panel (B) by using Screws JCA (RF10003) as show Diag 3.

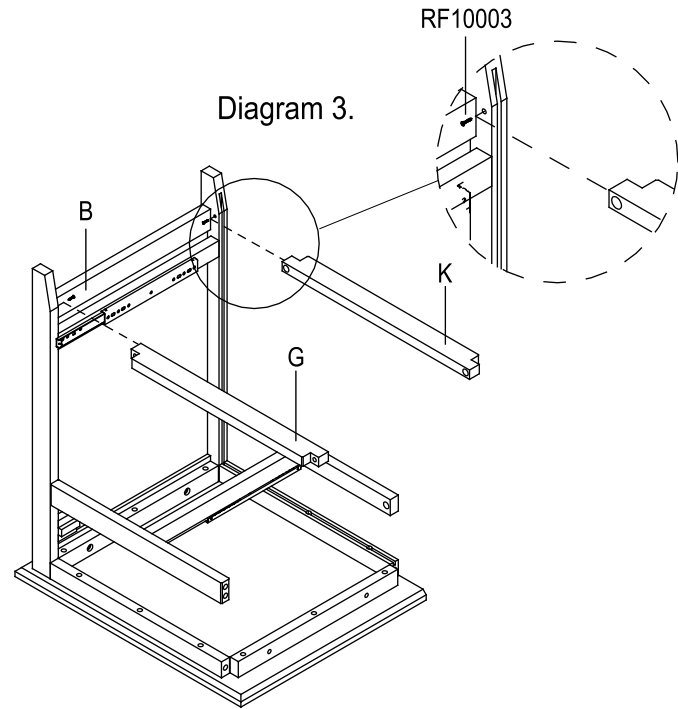

Step 4. Attach Back Panel (H) into at the grooves Table Top as show Diag 4.

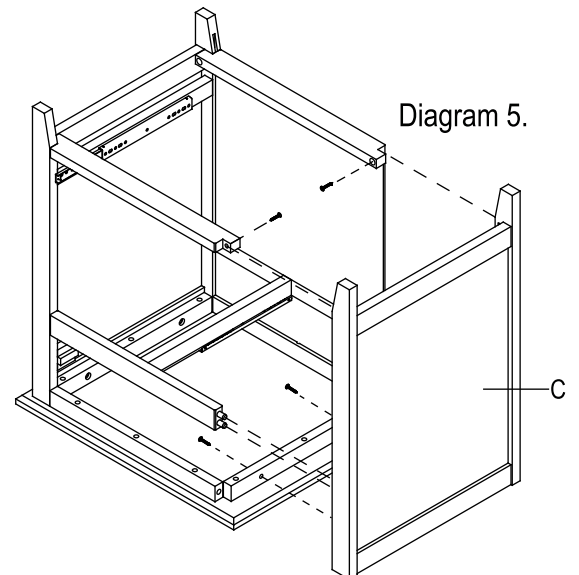
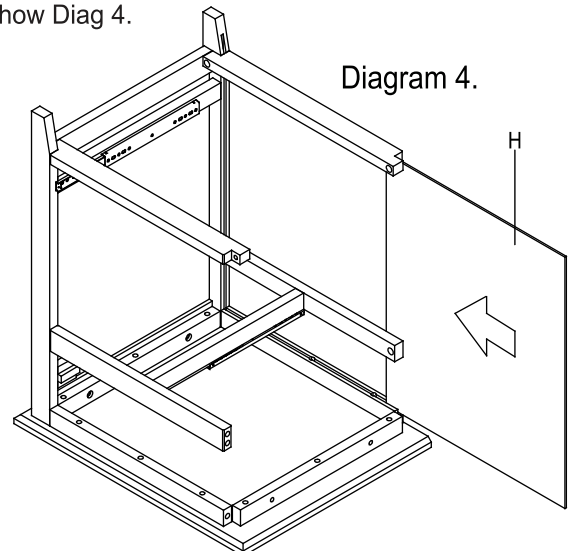

Step 5. Attach the Right Panel (C) by repeating step 1,2 and 3. as shown Diag.5.

Drawer I :
 Step 6 Attach Both Sides of Drawers (I1), Front Drawer (I2) and Back Drawer (I3) by using 8 Pcs of Screws F6 x 1 1/4" (RF10002) and attach the Pull Handle (RF40140) as show Diag 6.

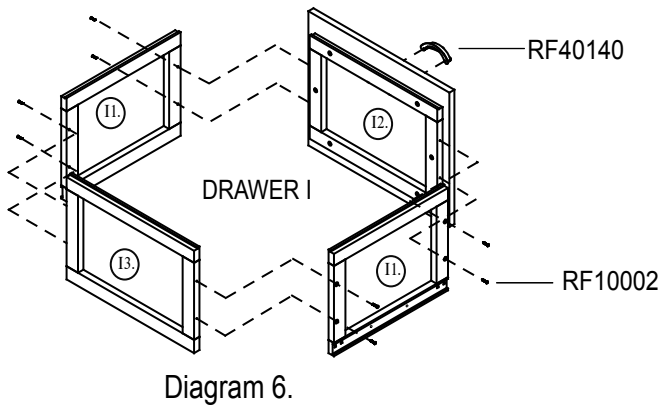

Step 9. Attach Drawer J using 2 Pcs of Screws F6 x 1/2" (RF10029) as show Diag 9.

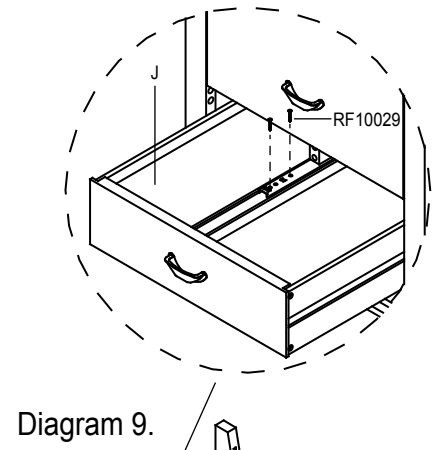

Drawer J:
 Step 7 Attach Both Sides of Drawers (J1), Front Drawer (J2), Back Drawer (J3), to Side Bottom (J4) insert Bottom Bar (J5) into at pre-drilling holes front & back drawer by using 8 Pcs of Screws F6 x 1" (RF10019) and attach the Pull Handle (RF40140) as show Diag 7.

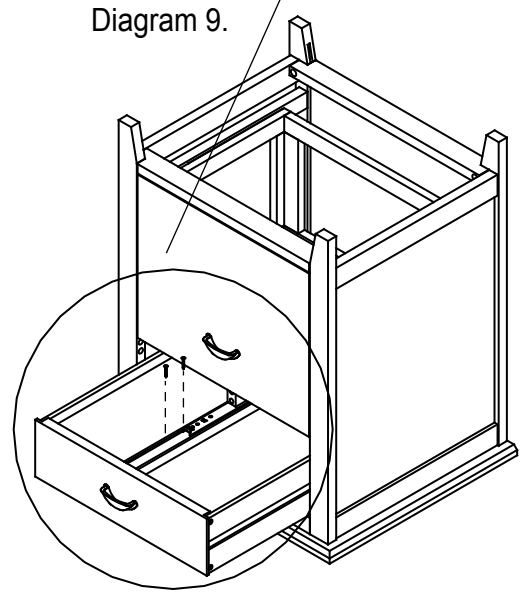
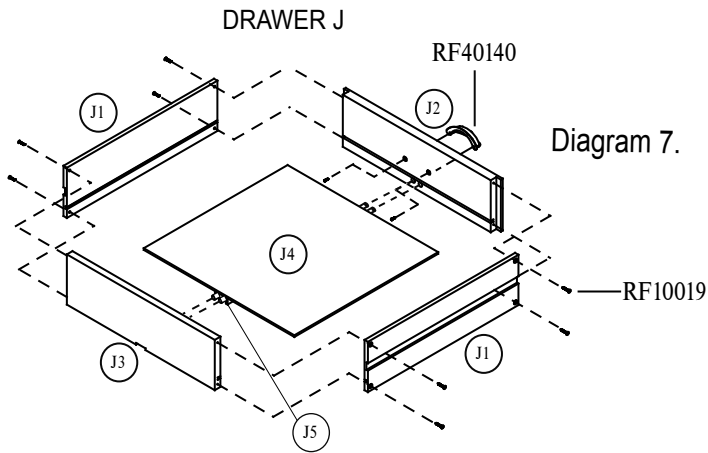

Step 8. Attach the Drawer I (I) using 4 Pcs of Sm screws F6 (RF10029) as show Diag 8.

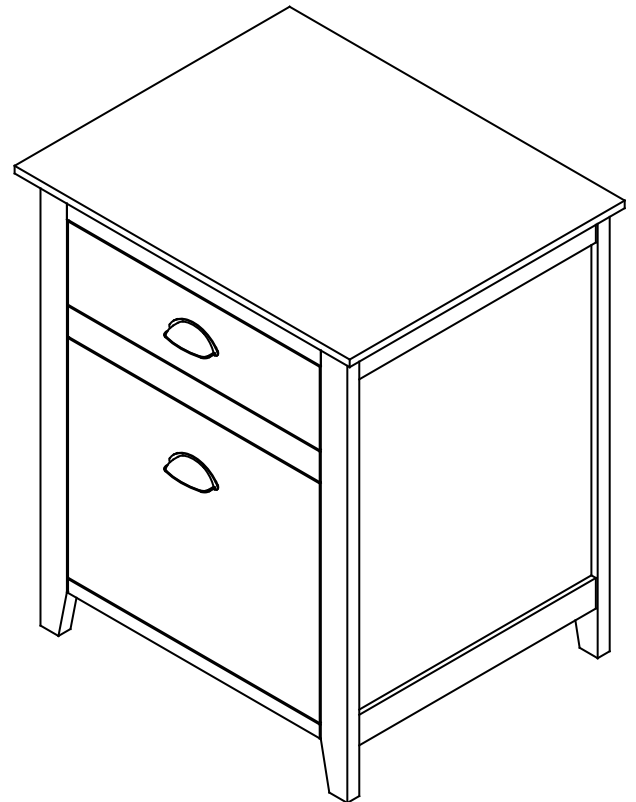
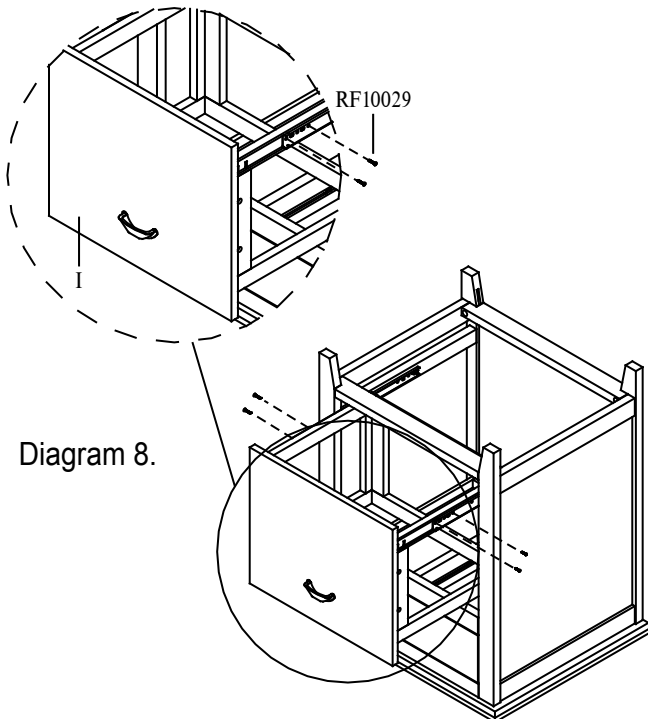

COMPLETE UNIT SET UP